

Lithium Button Cell Battery



Scope

This specification is applicable to RND Manganese Dioxide Lithium cell, CR2477

Law & Regulation Compliances

This product complies with EU's battery directive (2013/56/EU)

Packaging materials comply with EU's directive on packaging materials and waste (94/62/EC)

Specification

IEC / JIS	CR2477
Chemical System	Lithium/Manganese Dioxide (Li/MnO ₂)
Nominal Voltage	3 V
Weight	Approx. 8.7 g
Capacity	950 mAh
Discharge Mode	7.5 kOhm, 24 h/d, e.v. 2 V
Instantaneous Short-Cut Circuit	≥350 mA
Operation Temperature	-20 ... 60 °C
Recommended Storage	0 ... 40 °C, 55 +/- 20% RH
Quick Discharged Volume	950 hours

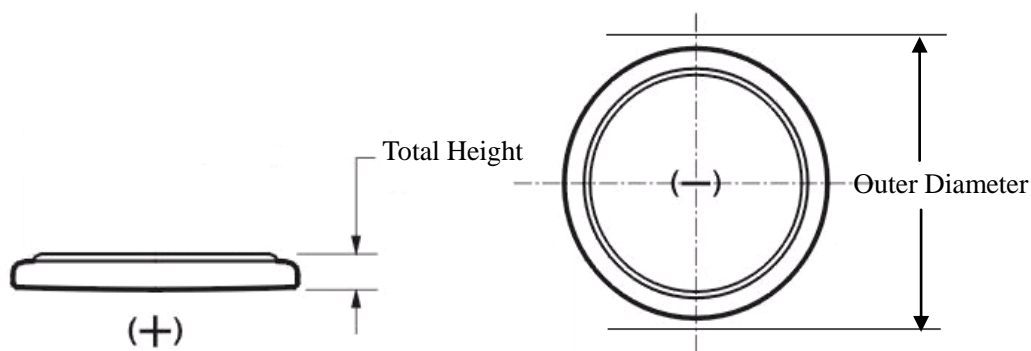

Outer Diameter	24.5 mm
Total Height	7.7 mm

Electrical Characteristics

Unless otherwise stated, all measurements are to be performed at a Standard Environment of 20°C±2 °C, 55±20% RH

All samples are normalized for 8 hours at least at the above environment prior to measurement.

The measurement accuracy for DCV shall be ±0.1% or better. The load resistance of the total circuit is accurate within ±0.5% of the specified value

Lithium Button Cell Battery



Open Circuit Voltage

	OCV(V)
Initial	3.25 ... 3.45 V

Service Output

Designation	CR2477
Load	7.5 K Ω
Test mode	24 h/d
End voltage	2 V
Initial MAD	2375 h

h: hour d: day

*The initial discharge test shall commence within 30 days of manufacture. During stored period, the cells shall be stored under 20 \pm 2 $^{\circ}$ C, RH55 \pm 20% conditions.

Expiry Period

5 years

Expiry Date Marking

Unless otherwise specified, one date code will be marked on the package plate of blisters or cards for finished cells. The date code will be followed by month and year of manufacturing for domestic and date code will be followed by month and year of expiry for export. (Shelf life 3 years)

Precautions in Handling of Lithium Batteries

Lithium batteries contain lithium metal, organic solvents and other reactive materials, which are combustible. Care must be exercised when handling Lithium batteries to ensure that short circuiting, puncturing or deformation does not occur which may result in heat generation, leakage, explosion or possibility a fire which might cause injury. To ensure safety and to avoid any possibility of any accidents, please observe the following precautions.

Do not insert batteries in reverse. Observe the + and – markings on battery and equipment. When batteries are inserted in reverse they may be short-circuited or charged. This may cause overheating, explosion, or fire.

Do not short-circuit batteries

When the positive (+) and negative (–) terminals of a battery are connected directly with each other, the battery becomes short-circuited. This can result in venting, leakage, and possibly fire.

Do not charge batteries

Attempting to charge a primary battery may cause internal gas and/or heat generation resulting in venting, explosion and possibly fire.

Do not force discharge batteries

When batteries are force discharged by means of an external power source, the voltage of the battery will be forced below its design capability and gases generated inside the battery. This may result in venting, leakage, explosion and possibly fire

Do not mix batteries

When replacing batteries, replace all of them at the same time with new batteries of the same brand and type. When batteries of different brand or type are used together or new and old batteries are used together, some batteries may be charged due to a difference of cell voltage or overdischarged due to a difference of capacity. This may result in venting and/or explosion.

Exhausted batteries should be immediately removed from equipment and disposed of.

When discharged batteries are kept in the equipment for a long time, electrolyte leakage may occur causing damage to the equipment.

Do not overheat batteries

When a battery is overheated, electrolyte may be released and separators may deteriorate. This may result in leakage, venting, explosion and possibly fire.

Do not weld or solder directly to batteries

The heat from welding or soldering directly to a battery may cause leakage, venting, explosion, or fire.

Do not dismantle batteries

When a battery is dismantled, the components may cause personal injury or fire.

Do not deform batteries

Lithium batteries should not be crushed, punctured, or otherwise mutilated. Such abuse may result in leakage, venting, explosion, or possibly fire.

Do not dispose of batteries in fire

When batteries are disposed of in fire, the heat build-up may cause explosion and/or fire. Do not incinerate batteries except for approved disposal in a controlled incinerator.

A lithium battery with a damaged container should not be exposed to water. Lithium metal in contact with water may produce fire and/or hydrogen gas.

Keep batteries out of the reach of children

Especially keep batteries which are considered swallowable out of the reach of children. In case of ingestion of a cell or battery, seek medical assistance promptly.